

# Concrete Embedment Strain Gages

## Applications

The Model 4200, 4202 and 4210 are designed to measure strains in or on...

- Foundations
- Piles
- Bridges
- Dams
- Containment vessels
- Tunnel liners
- Mass concrete with coarse aggregates
- Laboratories and/or where space limitations exist (Model 4202)



• Geokon Model 4200HT High Temperature Strain Gage.

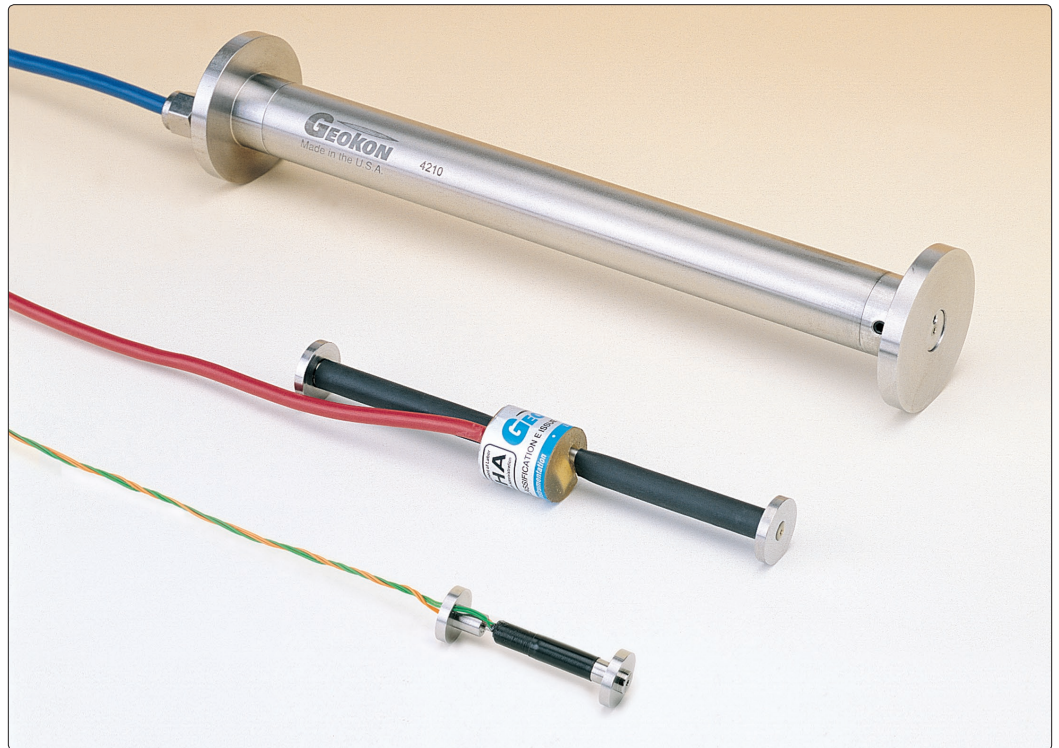

• Model 4202 (front), Model 4200 (center) and Model 4210 (rear) Concrete Embedment Strain Gages.

## Operating Principle

The Model 4200(HT), 4202 and 4210 Vibrating Wire Embedment Strain Gages are designed for direct embedment in concrete. The Model 4200 (standard model) has a 153 mm gage length and is commonly used for strain measurements in foundations, piles, bridges, dams, containment vessels, tunnel liners, etc. The Model 4210 has a 250 mm gage length and is designed for use in mass concrete with coarse aggregates. It is extra rugged to resist bending, and has large flanges to provide greater engagement area. The 4202, with a 51 mm gage length, is designed for laboratory use and/or where there are space limitations.

Strains are measured using the vibrating wire principle: a length of steel wire is tensioned between two end blocks that are embedded directly in concrete. Deformations (i.e. strain changes) of the concrete mass, will cause the two end blocks to move relative to one another, thus altering the tension in the steel wire. The tension is measured by plucking the wire and measuring its resonant frequency of vibration using an electromagnetic coil.

## Advantages and Limitations

The Model 4200 Series Strain Gages enjoy all the advantages of vibrating wire sensors: i.e., excellent long term stability, maximum resistance to the effects of water, and a frequency output suitable for transmission over very long cables.

All components are made from stainless steel for corrosion protection. The gages are fully waterproof. Models 4200(HT) and 4210 are very rugged and are designed to withstand the rigors of concrete placement.

Each gage also incorporates a thermistor so that the temperature can be read and displayed by the readout box.

High temperature versions (Model 4200HT) are available for use in steam-cured concrete piles.

The strain gages are not suitable for the measurement of dynamic (rapidly changing) strains.

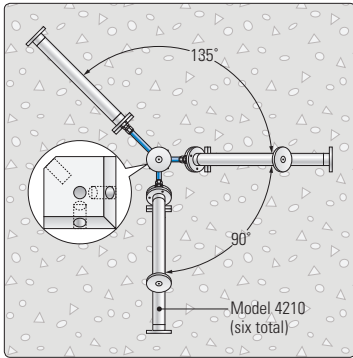

• Top view of a Model 4210 strain gage rosette configuration. Inset shows rosette fixture (enlarged for detail).

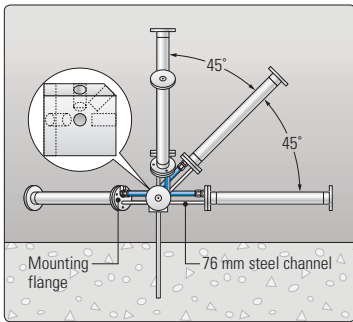

• Front view of a Model 4210 strain gage rosette configuration. Inset shows rosette fixture (enlarged for detail).

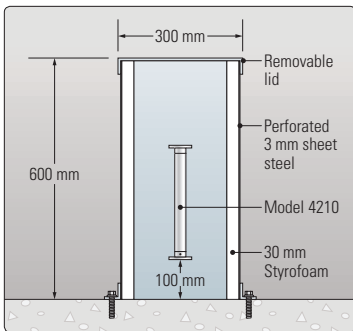

• "No stress-strain" enclosure using the Model 4210.

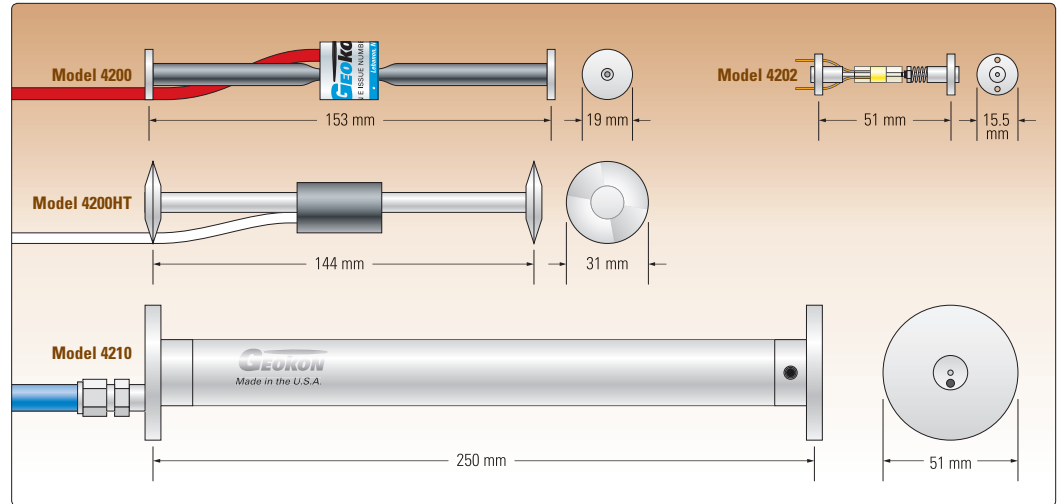

• Dimensions of the 4200 Series Strain Gages.

## System Components

The strain gages are shipped ready for installation with the correct amount of cable attached. Installation is accomplished by attaching the strain gage to any steel reinforcement bar, or, in mass concrete, to special rosette fixtures designed to hold multiple strain gages in different orientations to allow the measurement of strain in three dimensions.

Also available are no stress-strain enclosures for use in concrete dams. These enclosures are double-wall, sheet-steel containers, lined with Styrofoam, designed

to isolate one or more strain gages from the stress field in the concrete, and to allow an estimate of, and correction for the effects of moisture, temperature, autogenous growth, etc.

All models are equipped with integral thermistors for the simultaneous measurement of temperature.

Readout is accomplished using the Geokon Model GK-401, GK-403 or GK-404 Readout Boxes, which can, when used with the Model 4200, display the strain directly in microstrain.

## Technical Specifications

	4200	4200HT	4202	4210
Standard Range	3000 $\mu\epsilon$	3000 $\mu\epsilon$	3000 $\mu\epsilon$	3000 $\mu\epsilon$
Resolution	1.0 $\mu\epsilon$	1.0 $\mu\epsilon$	0.4 $\mu\epsilon$	0.4 $\mu\epsilon$
Accuracy <sup>1</sup>	$\pm 0.5\%$ F.S.	$\pm 0.5\%$ F.S.	$\pm 0.5\%$ F.S.	$\pm 0.5\%$ F.S.
Nonlinearity	< 0.5% F.S.	< 0.5% F.S.	< 0.5% F.S.	< 0.5% F.S.
Temperature Range	-20°C to +80°C	-20°C to +200°C	-20°C to +80°C	-20°C to +80°C
Active Gage Length	153 mm	144 mm	51 mm	250 mm <sup>2</sup>
Thermal Coefficient of Expansion	12.0 ppm/°C	12.0 ppm/°C	12.0 ppm/°C	12.0 ppm/°C
Coil Resistance	180 $\Omega$	120 $\Omega$	50 $\Omega$	180 $\Omega$
Cable Type	4 conductor shielded 22 awg (for all models)			
Frequency Datum <sup>3</sup>	800 Hz	800 Hz	2600 Hz	2600 Hz

<sup>1</sup> $\pm 0.5\%$  F.S. with standard batch calibration.  $\pm 0.1\%$  F.S. with individual calibration. Accuracy established under laboratory conditions.

<sup>2</sup>Other lengths available on request.

<sup>3</sup>Typical.



The World Leader in Vibrating Wire Technology™

Geokon, Incorporated  
48 Spencer Street  
Lebanon, NH 03766  
USA

Geokon maintains an ongoing policy of design review and reserves the right to amend products and specifications without notice.

1 • 603 • 448 • 1562  
1 • 603 • 448 • 3216  
geokon@geokon.com  
www.geokon.com

©2007 Geokon, Incorporated. All Rights Reserved | Doc. Rev. D, 07/07

